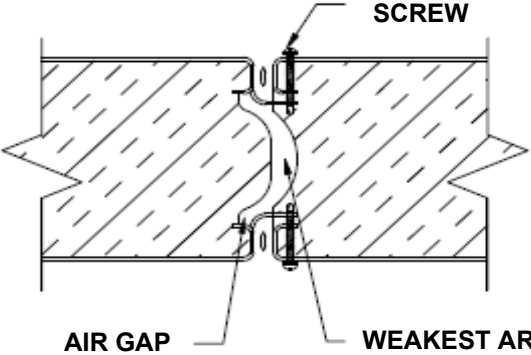

**COMMERCIAL COOLING
PAR ENGINEERING, INC.**

**BUYER BEWARE
ALL WALK-INS ARE NOT THE SAME**

RATING	INDUSTRY NOMENCLATURE	SKETCH	EXPLANATION OF MAJOR DIFFERENCES
<p><u>ACCEPTABLE</u></p> <div data-bbox="142 423 642 565" style="border: 1px solid black; padding: 10px; text-align: center; margin: 20px 0;">COMPETITOR</div>	<p>Soft Nose</p>		<p>Lowest strength at joint where needed the most. Joints expand or tear since nothing is holding them together except limited local adhesion of foam. Hard to line up panels</p>
