

**COMMERCIAL COOLING  
PAR ENGINEERING, INC.**

**BUYER BEWARE  
ALL WALK-INS ARE NOT THE SAME**

RATING	INDUSTRY NOMENCLATURE	SKETCH	EXPLANATION OF MAJOR DIFFERENCES
<u>POOR</u>	Wood frame with tongue and groove	 <p data-bbox="772 638 884 662"><b>AIR GAP</b></p> <p data-bbox="1073 638 1276 662"><b>UNEVEN EDGES</b></p>	<p data-bbox="1266 342 1986 415">Large gap at seams due to folded metal plus staples. 2 x 4 and 2 x 5 do not have close tolerances.</p> <p data-bbox="1266 456 1969 600">Panels always sweat around wood frame. Wood absorbs moisture and twist / turn wood is a poor insulator. High density foam rails cost 5 times more than wood.</p>

**COMPETITOR**

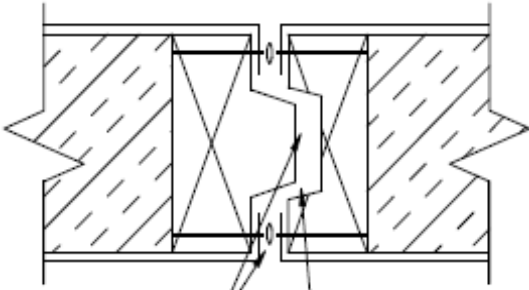